

## Ideal solution for connected sliding gates in homes and apartment blocks

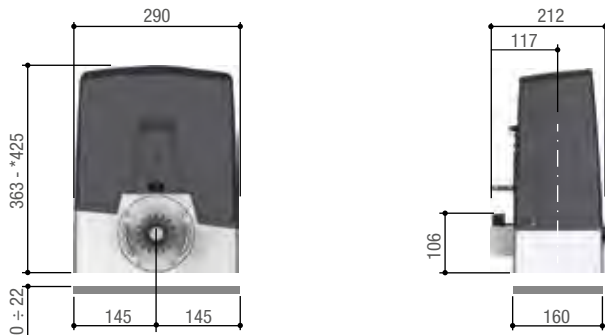

- 4 motors, all with encoder control also available in the Rapid and High version.
- The 400 and 600 kg versions comply with current standards on impact forces.
- Can operate in emergency mode during power outages.
- Can retrofit magnetic limit-switches and heater for extreme weather conditions.
- Electronic board, with separate terminal blocks and display, to facilitate start-up and diagnosis phases. Storing for up to 250 different users.
- Radio programming Rolling code and integrated Key Code (Twin).
- Management of the Rio series wireless security accessories using the dedicated plug-in accessory.
- Testing of safety circuits for CAT 2 safety products – whether wireless or not.
- Devices developed for connection to the cloud, via CAME Connect.
- Used to directly manage CAME key pads using the R800 accessory or connect CAME transponder selectors using the R700 accessory.
- Connection used with the RSE accessory.

### Dimensions (mm)



\* 801MS-0170 - 801MS-0200 - 801MS-0220 - 801MS-0240

### Battery types

MODEL	BATTERY TYPE (not supplied)	MODEL	BATTERY TYPE (not supplied)
801MS-0150	2 x 12 V - 1.3 Ah	801MS-0210	2 x 12 V - 1.3 Ah
801MS-0170	2 x 12 V - 5 Ah	801MS-0220	2 x 12 V - 5 Ah
801MS-0160	2 x 12 V - 5 Ah	801MS-0230	2 x 12 V - 1.3 Ah
801MS-0180	2 x 12 V - 1.3 Ah	801MS-0240	2 x 12 V - 5 Ah
801MS-0200	2 x 12 V - 5 Ah	801MS-0250	2 x 12 V - 5 Ah
801MS-0190	2 x 12 V - 5 Ah		

### Technical characteristics

MODELS	801MS-0150	801MS-0180	801MS-0210	801MS-0230	801MS-0170	801MS-0200	801MS-0220	801MS-0240
Protection rating (IP)	44	44	44	44	44	44	44	44
Power supply (V - 50/60 Hz)	230 AC	230 AC	230 AC	230 AC	230 AC	230 AC	230 AC	230 AC
Power supply to motor (V)	24 DC	24 DC	24 DC	24 DC	24 DC	24 DC	24 DC	24 DC
Absorption (A)	7 MAX	11 MAX	16 MAX	16 MAX	7 MAX	11 MAX	16 MAX	16 MAX
Power (W)	170	270	400	400	170	270	400	400
Duty/cycle (%)	HEAVY-DUTY SERVICE	HEAVY-DUTY SERVICE	HEAVY-DUTY SERVICE	HEAVY-DUTY SERVICE	HEAVY-DUTY SERVICE	HEAVY-DUTY SERVICE	HEAVY-DUTY SERVICE	HEAVY-DUTY SERVICE
Thrust (N)	350	600	800	1000	350	600	800	1000
Operating temperature (°C)	-20 ÷ +55	-20 ÷ +55	-20 ÷ +55	-20 ÷ +55	-20 ÷ +55	-20 ÷ +55	-20 ÷ +55	-20 ÷ +55
MODELS		801MS-0160	801MS-0190	801MS-0250	801MS-0260	801MS-0270	801MS-0280	801MS-0290
Protection rating (IP)		44	44	44	44	44	44	44
Power supply (V - 50/60 Hz)		230 AC	230 AC	230 AC	110 AC	110 AC	110 AC	110 AC
Power supply to motor (V)		24 DC	24 DC	24 DC	24 DC	24 DC	24 DC	24 DC
Absorption (A)		10 MAX	10 MAX	16 MAX	7 MAX	11 MAX	16 MAX	16 MAX
Power (W)		240	240	360	170	270	400	400
Duty/cycle (%)		HEAVY-DUTY SERVICE	HEAVY-DUTY SERVICE	HEAVY-DUTY SERVICE	HEAVY-DUTY SERVICE	HEAVY-DUTY SERVICE	HEAVY-DUTY SERVICE	HEAVY-DUTY SERVICE
Thrust (N)		250	330	450	350	600	800	1000
Operating temperature (°C)		-20 ÷ +55	-20 ÷ +55	-20 ÷ +55	-20 ÷ +55	-20 ÷ +55	-20 ÷ +55	-20 ÷ +55